

MS560D

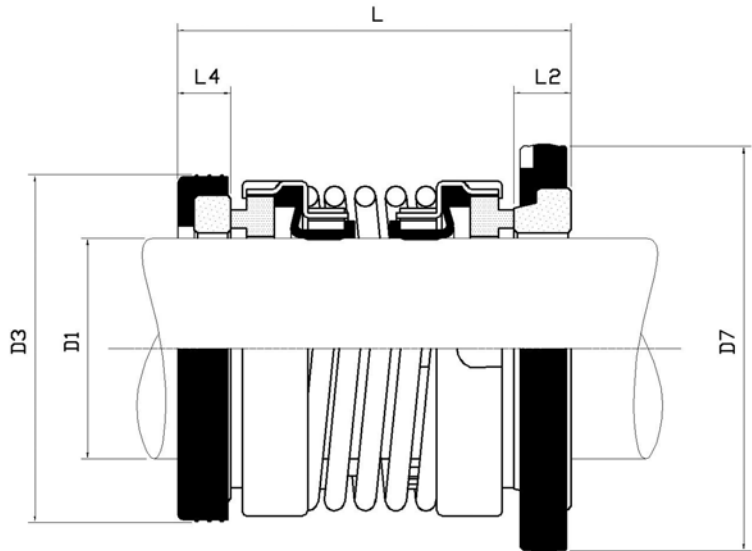

Design Features

Back to back seal configuration in oil chamber, silicon carbide seal face on the impeller side commonly found in submersible pumps

Operating Conditions

Temperature: -30°C to +200°C
(Depending on materials used)

Pressure: Up to 5 bar, 75 psi

Speed: Up to 5m/s, 1000rpm

Materials available

Seal face: carbon, ceramic, SIC

Elastomer: nitrile, viton.

Equivalent to

ED560 seal

D1	D3	D7	L2	L4	L
14mm	30	30	4.0	4.0	36
15mm	30	30	4.0	4.0	36
16mm					
18mm	34	38			
20mm	38	44	7.5	8.6	50
20mm	38	38			50
24mm	39	44			
24mm	38	50			
25mm	44	50	8.0	8.6	50
25mm	44	44			50
30mm	44	57	10.7	10.7	60
30mm	50	57			60
35mm	54	57	10.7	10.7	60
35mm	58	64			60
35mm	58	58			60
40mm	68	70	12.0	12.0	65
40mm	64	70	11.5	11.5	65
45mm	68	70	12.0	12.0	65